

250V N-Ch Power MOSFET

Feature

- ◇ High Speed Power Smooth Switching, Logic Level
- ◇ Enhanced Body diode dv/dt capability
- ◇ Enhanced Avalanche Ruggedness
- ◇ 100% UIS Tested, 100% Rg Tested
- ◇ Lead Free

Application

- ◇ Synchronous Rectification in SMPS
- ◇ Hard Switching and High Speed Circuit
- ◇ Power Tools
- ◇ UPS
- ◇ Motor Control

V_{DS}		250	V
$R_{DS(on),typ}$	$V_{GS}=10V$	87	$m\Omega$
$R_{DS(on),typ}$	$V_{GS}=4.5V$	93	$m\Omega$
I_D		25	A

TO-220

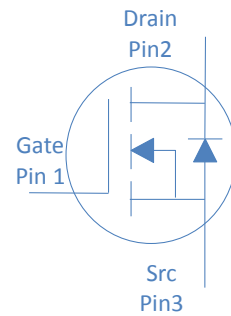

Part Number	Package	Marking
HGP1K2N25ML	TO-220	GP1K2N25ML

Absolute Maximum Ratings at $T_j=25^\circ\text{C}$ (unless otherwise specified)

Parameter	Symbol	Conditions	Value	Unit
Continuous Drain Current	I_D	$T_C=25^\circ\text{C}$	25	A
		$T_C=100^\circ\text{C}$	17.6	
Drain to Source Voltage	V_{DS}	-	250	V
Gate to Source Voltage	V_{GS}	-	± 20	V
Pulsed Drain Current	I_{DM}	-	32	A
Avalanche Energy, Single Pulse	E_{AS}	$L=0.4\text{mH}, T_C=25^\circ\text{C}$	1.8	mJ
Power Dissipation	P_D	$T_C=25^\circ\text{C}$	167	W
Operating and Storage Temperature	T_J, T_{stg}	-	-55 to 175	$^\circ\text{C}$

Absolute Maximum Ratings

Parameter	Symbol	Max	Unit
Thermal Resistance Junction-Case	$R_{\theta JC}$	0.9	$^\circ\text{C/W}$
Thermal Resistance Junction-Ambient	$R_{\theta JA}$	46	$^\circ\text{C/W}$

Electrical Characteristics at T_j=25°C (unless otherwise specified)
Static Characteristics

Parameter	Symbol	Conditions	Value			Unit
			min	typ	max	
Drain to Source Breakdown Voltage	V _{(BR)DSS}	V _{GS} =0V, I _D =250μA	250	-	-	V
Gate Threshold Voltage	V _{GS(th)}	V _{GS} =V _{DS} , I _D =250μA	1	2.1	3	
Zero Gate Voltage Drain Current	I _{DSS}	V _{GS} =0V, V _{DS} =250V, T _j =25°C	-	-	1	μA
		V _{GS} =0V, V _{DS} =250V, T _j =100°C	-	-	100	
Gate to Source Leakage Current	I _{GSS}	V _{GS} =±20V, V _{DS} =0V	-	-	±100	nA
Drain to Source on Resistance	R _{DS(on)}	V _{GS} =10V, I _D =6A	-	87	120	mΩ
	R _{DS(on)}	V _{GS} =4.5V, I _D =4A	-	93	140	mΩ
Transconductance	g _{fs}	V _{DS} =5V, I _D =20A	-	25	-	S
Gate Resistance	R _G	V _{GS} =0V, V _{DS} Open, f=1MHz	-	5.3	-	Ω

Dynamic Characteristics

Input Capacitance	C _{iss}	V _{GS} =0V, V _{DS} =125V, f=1MHz	-	980	-	pF
Output Capacitance	C _{oss}		-	24	-	
Reverse Transfer Capacitance	C _{rss}		-	8.4	-	
Total Gate Charge	Q _g (10V)	V _{DD} =125V, I _D =6A, V _{GS} =10V	-	20	-	nC
Total Gate Charge	Q _g (4.5V)		-	12	-	
Gate to Source Charge	Q _{gs}		-	3.2	-	
Gate to Drain (Miller) Charge	Q _{gd}		-	7.2	-	
Turn on Delay Time	t _{d(on)}	V _{DD} =125V, I _D =6A, V _{GS} =10V, R _G =10Ω,	-	18	-	ns
Rise time	t _r		-	10	-	
Turn off Delay Time	t _{d(off)}		-	28	-	
Fall Time	t _f		-	9	-	

Reverse Diode Characteristics

Diode Forward Voltage	V _{SD}	V _{GS} =0V, I _F =20A	-	0.9	1.2	V
Reverse Recovery Time	t _{rr}	V _R =125V, I _F =6A, dI _F /dt=100A/μs	-	80	-	ns
Reverse Recovery Charge	Q _{rr}		-	164	-	nC

Fig 1. Typical Output Characteristics

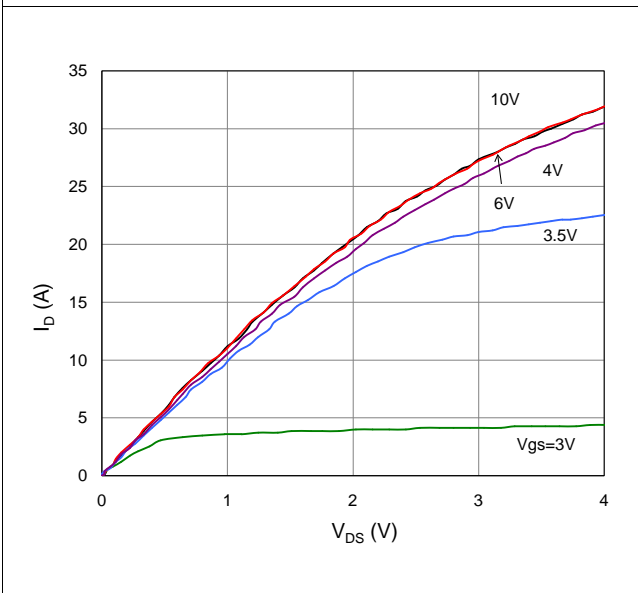

Figure 2. On-Resistance vs. Gate-Source Voltage

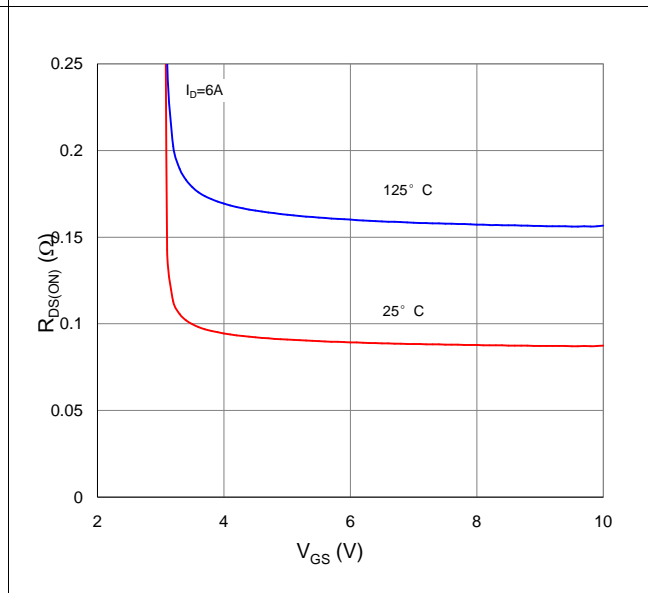

Figure 3. On-Resistance vs. Drain Current and Gate Voltage

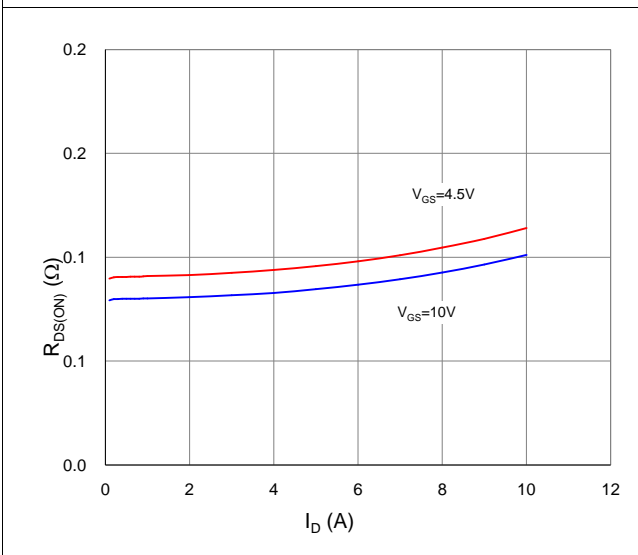

Figure 4. Normalized On-Resistance vs. Junction Temperature

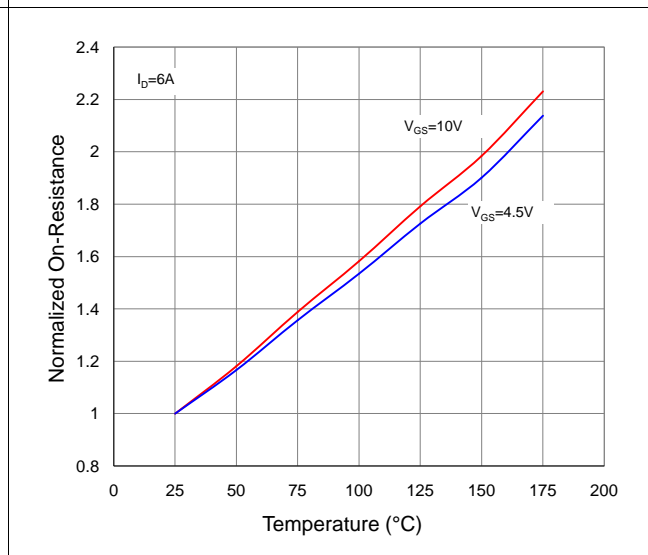

Figure 5. Typical Transfer Characteristics

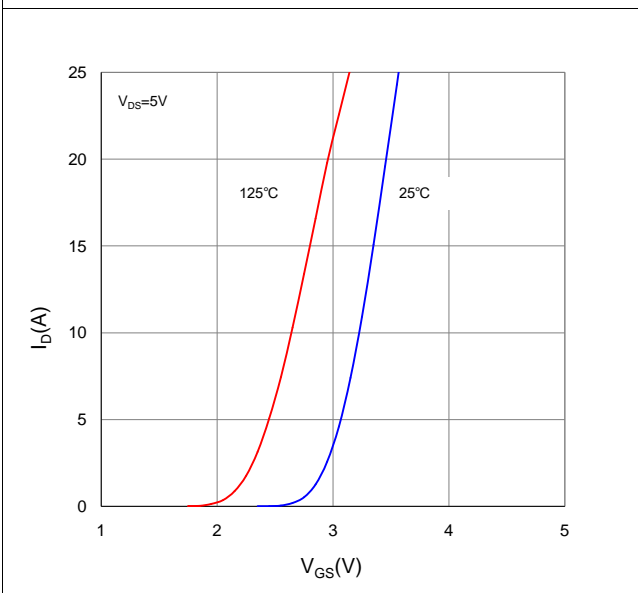

Figure 6. Typical Source-Drain Diode Forward Voltage

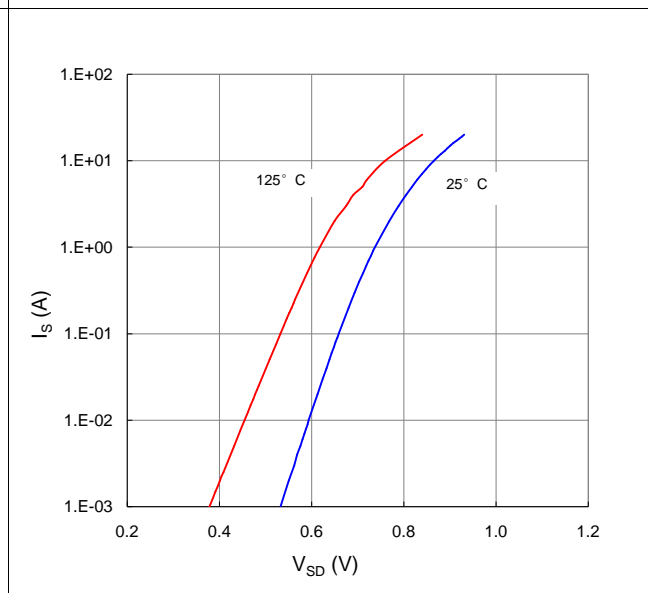

Figure 7. Typical Gate-Charge vs. Gate-to-Source Voltage

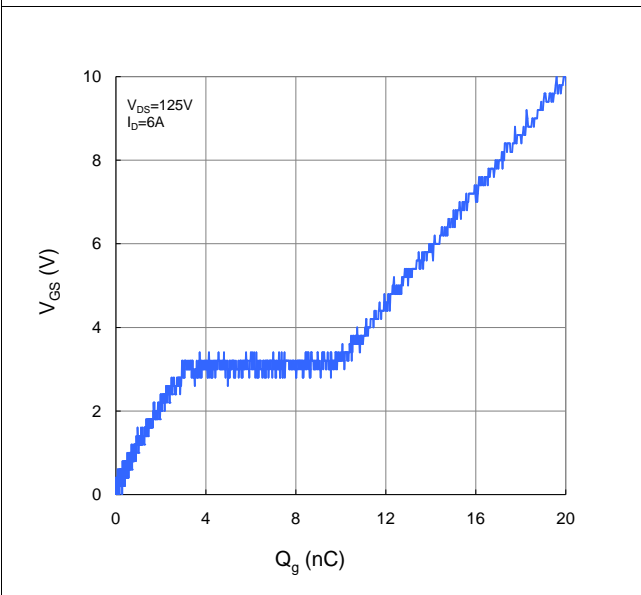

Figure 8. Typical Capacitance vs. Drain-to-Source Voltage

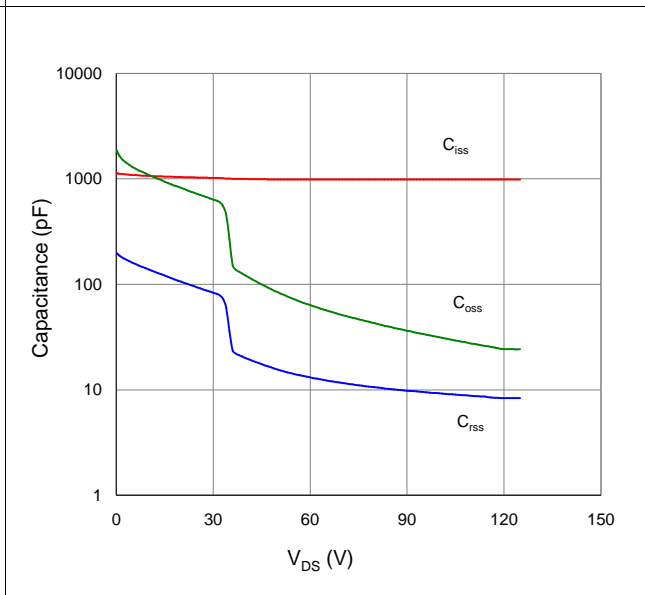

Figure 9. Maximum Safe Operating Area

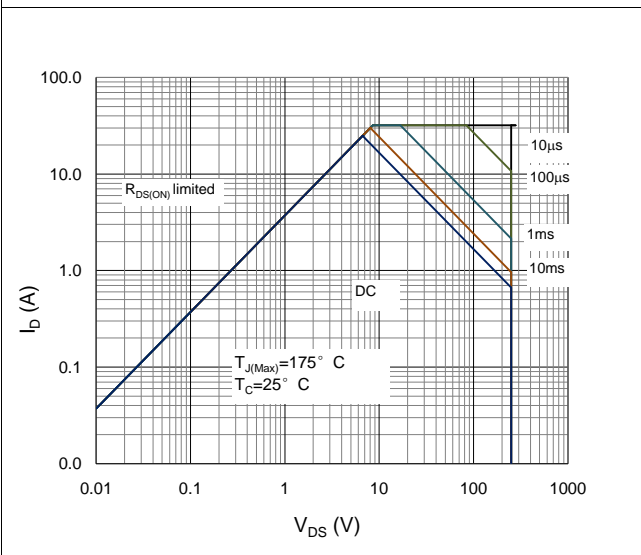

Figure 10. Maximum Drain Current vs. Case Temperature

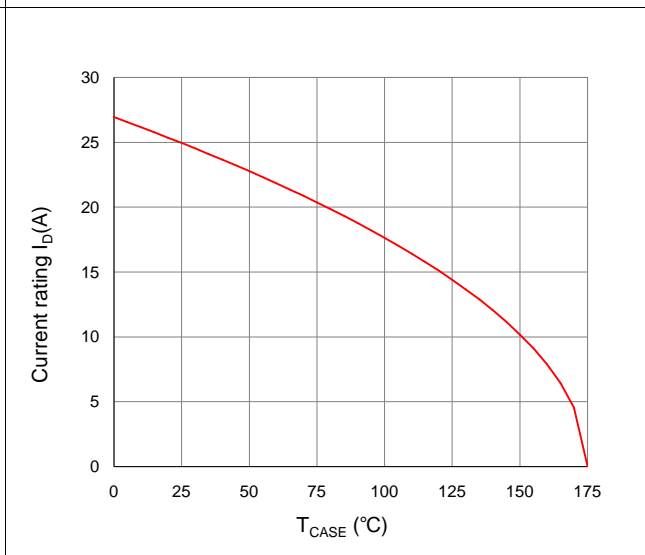
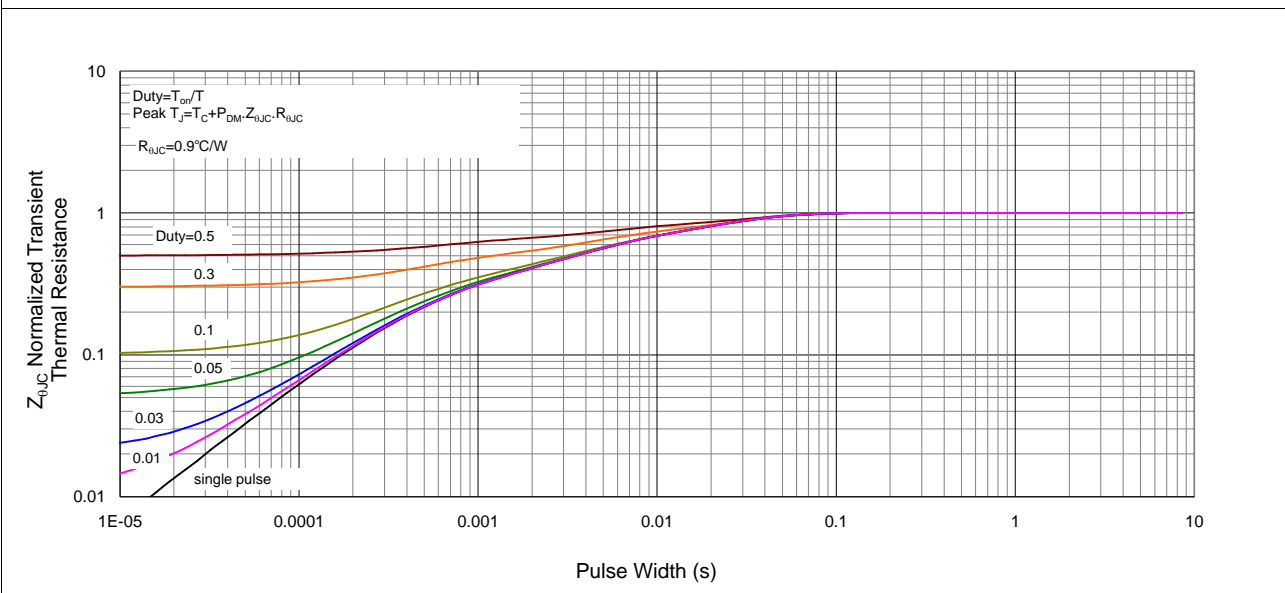
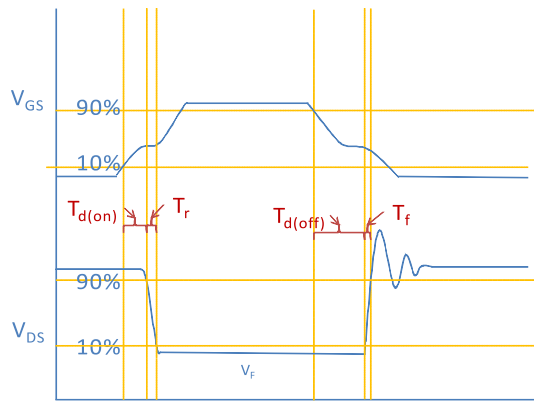
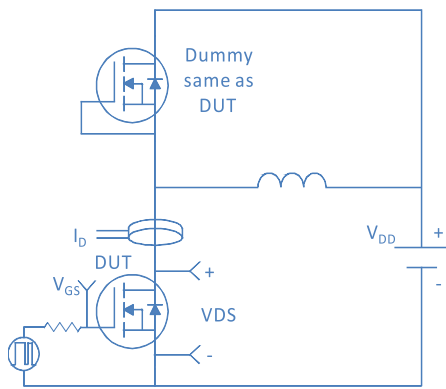

Figure 11. Normalized Maximum Transient Thermal Impedance, Junction-to-Case



Inductive switching Test



Gate Charge Test

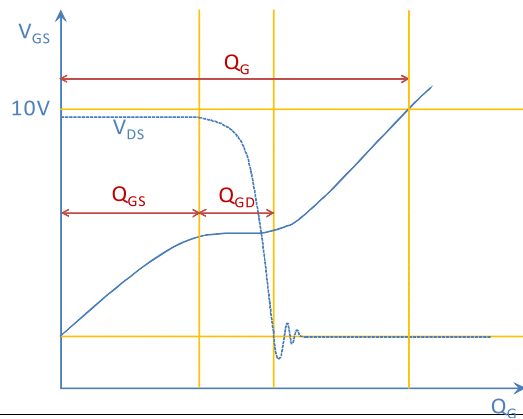
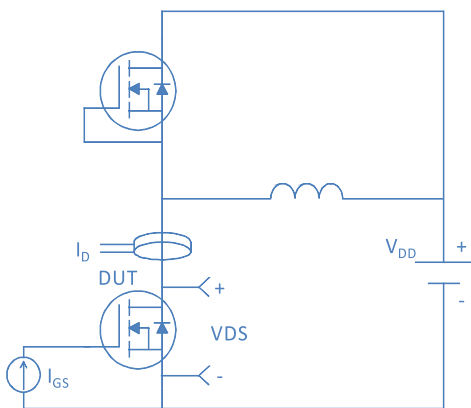

Uclamped Inductive Switching (UIS) Test

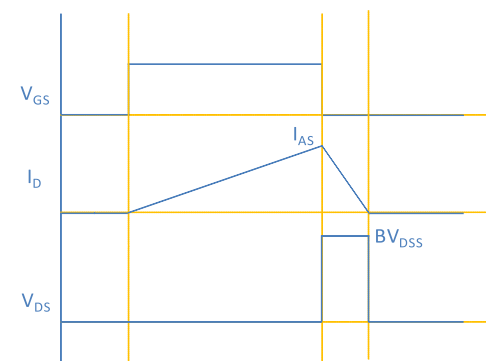
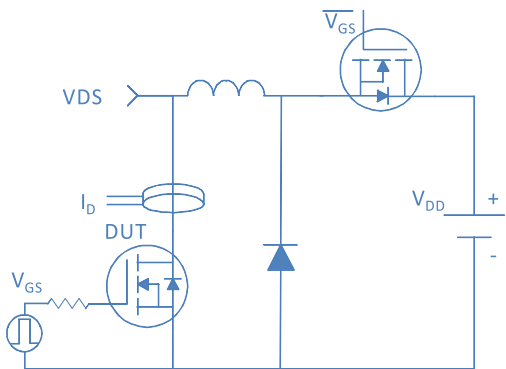

Diode Recovery Test

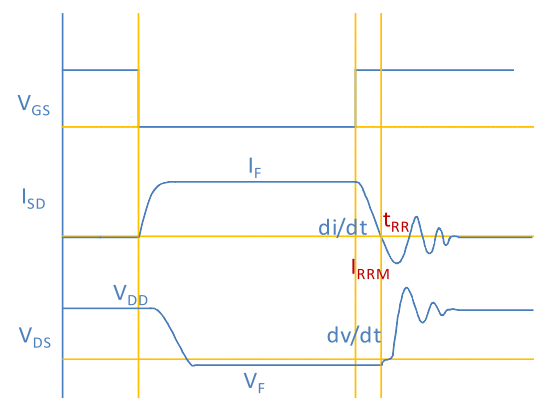
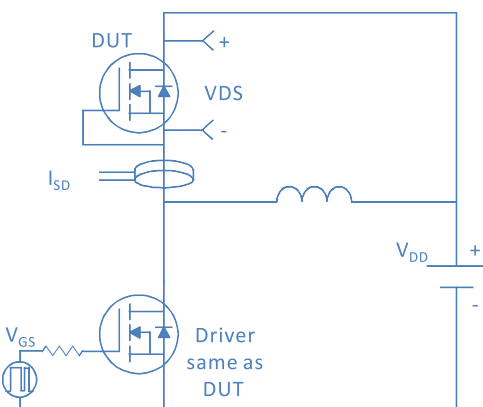

TO-220, 3 leads

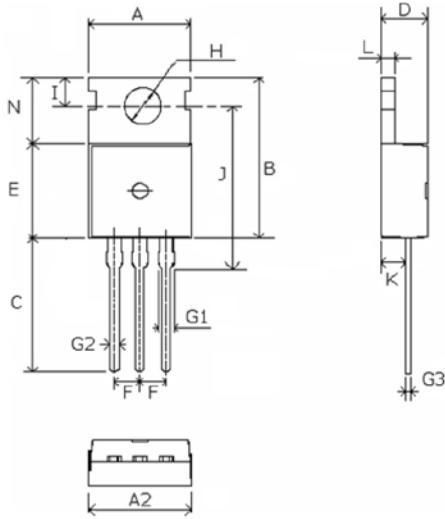

Dimensions in mm unless otherwise specified

Symbol	Min	Nom	Max
A	9.66	9.97	10.28
A2	9.80	10.00	10.20
B	15.60	15.70	15.80
C	12.70	13.48	14.27
D	4.30	4.50	4.70
E	9.00	9.20	9.40
F		2.54	
G1	1.32	1.52	1.72
G2	0.70	0.82	0.95
G3	0.45	0.52	0.60
H	3.50	3.60	3.70
I	2.70	2.80	2.90
J	15.70	15.97	16.25
K	2.20	2.40	2.60
L	1.15	1.27	1.40
N	6.40	6.60	6.80